

Implementing ISO 9126 in Quality Testing for Information Systems for Menu Ordering Using QR Codes in Panongkrongan Shop

Alvin Triyanto¹, Gia Prisilia², Yogi Saputra

^{1,2}Information System Department, Politeknik Negeri Subang, Indonesia

³Department of Informatics UIN Sunan Gunung Djati Bandung, Indonesia

Article Info

Article history:

Received February 16, 2023

Revised March 03, 2023

Accepted March 24, 2023

Keywords:

ISO 9126

Quality Testing

ABSTRACT

Panongkrongan Shop is a business that emphasizes the quality of its service. The limited number of employees serving customers has an impact on services that are not optimal, such as ordering errors, delays in ordering menus, price discrepancies because prices are not updated on the menu, transaction errors, and are also prone to loss of order data because the recording is still done manually. A menu ordering system can be built to reduce this problem. However, in its use, the system must be of good quality to support the store's operational activities. The poor quality of the system can cause errors so that those who use it can experience financial losses. For this reason, it is necessary to develop a quality measurement system to run correctly and meet ISO 9126 quality standards. Based on the test results, the system meets ISO 9126 standards with a total score of 91.9% with a functionality aspect of 95.3%, reliability of 83.7%, usability of 93.5%, efficiency of 89.0%, and portability of 98%. Improvements are needed in the reliability aspect, namely in maturity and fault tolerance, so that the system can be even better in terms of quality for error handling and maturity.

This is an open access article under the [CC BY-SA](https://creativecommons.org/licenses/by-sa/4.0/) license.



Corresponding Author:

Alvin Triyanto

Information System Department, Politeknik Negeri Subang

Jl. Brigjen Katamso No.37, Dangdeur, Kec. Subang, Kabupaten Subang, Jawa Barat 41211, Indonesia

Email: alvintriyanto2002@gmail.com

1. INTRODUCTION

The rise of the established cafe business has made business competition in the Food and Beverage even tighter. Each cafe competes to provide the best service with sales techniques that are advancing daily. Panongkrongan is a café in Subang Regency with three employees: one cashier and two kitchen staff. Based on Rika's statement (19) in an interview, the average Panongkrongan was visited by 20-50 customers every day with an age range of 16-30 years. The limited number of employees to serve customers has an impact on services that are not optimal, such as ordering errors, delays in ordering menus, price discrepancies because prices are not updated on the menu, transaction errors, and are also prone to loss of order data because the recording is still done [1]. Problems at the Panongkrongan include ordering menus that are still done manually, recording transactions is still manual, and payments do not serve the cashless method, causing errors in order, recording, and processing other transactions. So, it is necessary to have an Information System for Menu Ordering at the Panongkrongan.

Developing an information system will not go well if the system's quality is not good. Therefore, it is necessary to analyze and measure the quality of information systems with existing standards, one of which is the ISO 9126 quality standard. Based on [2] research, selecting ISO 9126 quality standards to be applied to B2C systems is very suitable for evaluating the performance of e-commerce systems built to make it easier to serve user needs. Each factor measured produces a different percentage so that it can be seen which factors need further development. Research conducted by [3] using ISO 9126 resulted in a percentage of 85.98% in the excellent category, whether the system was feasible.

This study aims to measure the quality of the menu ordering information system accessed via QR-Code and examine the main factors supporting the system's success using ISO 9126.

2. METHODOLOGY

2.1. ISO 9126

There are international standards for ensuring the quality of software products. The quality standard is the expected suitability of the software to be built in terms of functionality, software development standards, and the characteristics of the software itself, often referred to as the quality model. The quality model determines the requirements and evaluates software quality [4].

2.2. Research Phases

The steps used in Testing the Quality of an Information System for Menu Ordering Using a QR Code in a Food Store Business Using ISO 9120 are shown in Figure 1.

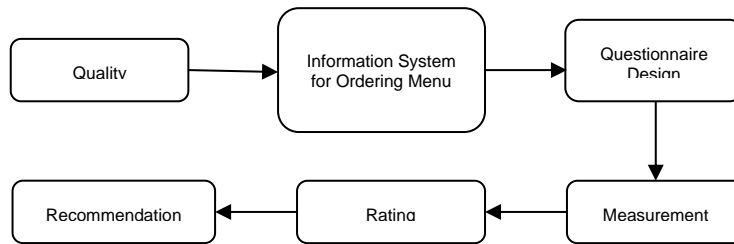

Figure 1. Research Phases Diagram [5]

a. Quality Requirement Definition

This phase aims to provide an overview of the factors and sub-factors used in the research. The first step is to define each factor and sub-factor, whether it is feasible or not for further.

Table 1. Factor and Sub-Factor of ISO 9126 [6]

Factor	Sub-Factor
Functional	Suitability
	Accurateness
	Security
Usability	Understandability
	Learnability
	Operability
Reliability	Attractiveness
	Fault Tolerance
	Recovery
Efficiency	Time Behavior
	Resource Utilization
Portability	Adaptability

b. Questionnaire Design

Questionnaires are made based on predetermined factors. The five factors have their respective sub-factors, which will be made into statement items for respondents. This study's respondents were 30, with three employees of Panongkrongan and 27 customers of Panongkrongan.

Table 2. Questionnaire Measurement Indicators

Measurement Indicators
The software performs the required task.
The software displays a menu according to what is input.
The software is equipped with suitable security measures. For example, the software cannot be accessed if you don't scan the QR Code.
The software can be understood easily.
Every feature of the software can be learned quickly.
Software is operated with minimum effort (Effortless).
The software has an attractive appearance.
The software can display a warning if the column is not filled.
The software can still run properly if there is an error.
The software can shorten the time in business processes.
The software only requires a few resources.
The software can adapt to other devices, such as Smartphones (IOS and Android) or PC (Windows and Mac)

c. Measurement

A total score is needed to measure each factor, which will be used as a reference for determining quality categories. The total score is obtained by adding up all the values of each item statement for each item.

d. Rating

To change the raw data obtained, namely in the form of numbers, into one meaning, a measurement scale is needed to interpret these numbers. This study adopted the measurement scale using the Likert scale interpretation.

The Likert scale is a scale designed to assess the extent to which subjects or respondents agree or disagree with statements on a 5-point scale with the following arrangement:

Table 3. Scoring Likert-Scale [7]

Answer	Score
Strongly agree	5
Agree	4
Neutral	3
Disagree	2
Strongly disagree	1

Table 4. Likert Scale Conversion [8]

No	%	Criteria
1	0.00-20.00	Not good
2	20.1-52.00	Less good
3	52.01-68.00	Pretty good
4	68.01-84.00	Good
5	84.01-100.00	Very good

e. Recommendation

To make a good recommendation, the entire domain in ISO 9126 must have been tested and seen which factors and sub-factors are appropriate for recommendation [9]. In this study, the recommendations were obtained from testing the three characteristics of ISO 9126 and the results of testing each item of the five factors used.

3. RESULT AND DISCUSSION

3.1. Analysis

The information system will not be separated from the database as the storage of all related data. Figure 2 is an Entity Relationship Diagram (ERD) in which there are six entities: customer, product, category, order, cashier, and expenses. This ERD has four relations: choosing, owning, storing, and recording. From this ERD, a table structure can be formed in the database, creating as many as seven tables.

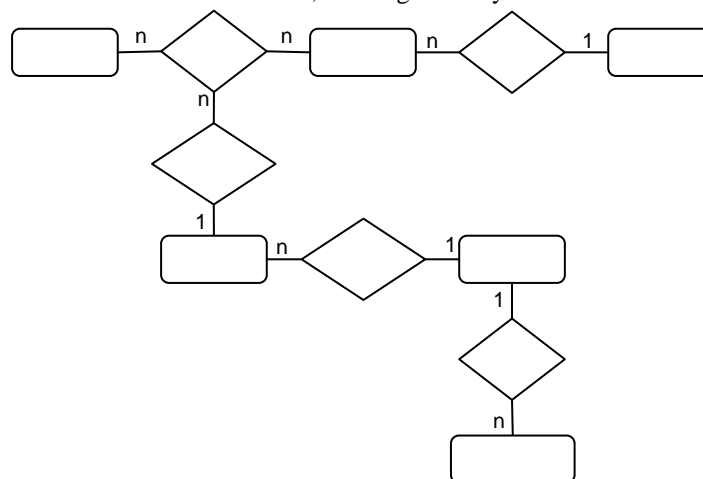

Figure 2. Entity Relational Diagram (ERD)

The display in this system is in accordance with the number of actors where a cashier page can be accessed on a desktop, and a customer page can be accessed on a mobile phone.

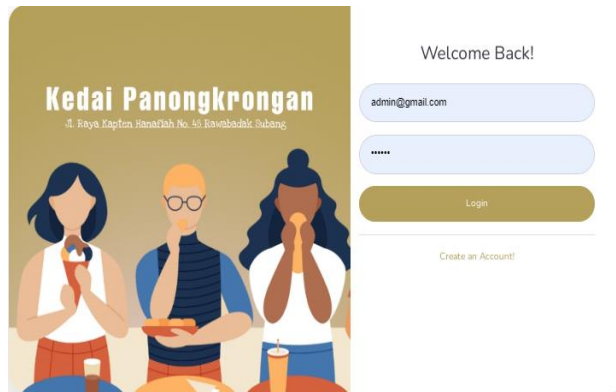

Figure 3. Cashier Login Page



Figure 4. Cashier Dashboard page

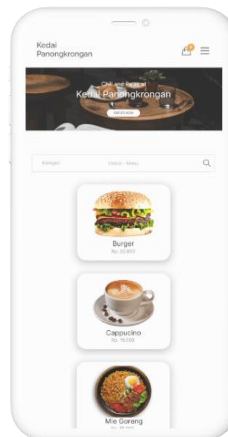

Figure 5. Customer Menu Page

3.2. ISO 9126 Testing

The results of software quality testing consist of two parts, namely the quality level of each aspect based on the five factors of ISO 9126 and the overall quality level of the five factors of ISO 9126.

Of the 30 respondents who filled out a questionnaire for testing the quality of a menu ordering information system using a QR-Code at the Panongkrongan, all provided valid questionnaire answers. Respondents' responses to the level of software quality, according to ISO 9126, can be measured using the following formula:

$$\% \text{ Ideal Score} = \frac{\text{Actual Score}}{\text{Ideal Score}} \times 100\%$$

- a. The actual score is the answer of all respondents to the questionnaire that has been submitted. The number of answers is multiplied by the weight of the Likert scale.

- b. The ideal score is the highest, or all respondents are assumed to choose the answer with the highest score [10].

Table 5. Respondents' Responses Based on Functionality Aspects

Answer Criteria	Weight	Functionality			Total
		Suitability	Accuracy	Security	
Strongly agree	5	24	23	24	71
Agree	4	5	6	6	17
Neutral	3	1	1	0	2
Disagree	2	0	0	0	0
Strongly disagree	1	0	0	0	0
Number of Respondents		30	30	30	90
Actual Score		143	142	144	429
Ideal Score		150	150	150	450

$$\% \text{ Ideal Score} = \frac{\text{Actual Score}}{\text{Ideal Score}} \times 100\%$$

$$\% \text{ Ideal Score} = \frac{429}{450} \times 100\%$$

$$\% \text{ Ideal Score} = 95,3\%$$

Respondents' responses based on functionality are the software's ability to provide functions according to user needs when used under certain conditions [11].

Table 6. Respondents' Responses Based on Usability Aspects

Answer Criteria	Weight	Usability				Total
		Understand-ability	Learn-ability	Oper-ability	Attractive-ness	
Strongly agree	5	21	24	13	27	85
Agree	4	7	5	16	3	31
Neutral	3	2	1	1	0	4
Disagree	2	0	0	0	0	0
Strongly disagree	1	0	0	0	0	0
Number of Respondents		30	30	30	30	120
Actual Score		139	143	132	147	561
Ideal Score		150	150	150	150	600

$$\% \text{ Ideal Score} = \frac{\text{Actual Score}}{\text{Ideal Score}} \times 100\%$$

$$\% \text{ Ideal Score} = \frac{561}{600} \times 100\%$$

$$\% \text{ Ideal Score} = 93,5\%$$

Respondents' responses based on the usability aspect are the ability of the software to be understood, studied, used, and attractive to users when used under certain conditions [11].

Table 7. Respondents' Responses Based on Reliability Aspects

Answer Criteria	Weight	Reliability		Total
		Maturity	Fault Tolerance	
Strongly agree	5	10	14	24
Agree	4	14	9	23
Neutral	3	6	7	13
Disagree	2	0	0	0
Strongly disagree	1	0	0	0
Number of Respondents		30	30	60
Actual Score		124	127	251
Ideal Score		150	150	300

$$\% \text{ Ideal Score} = \frac{\text{Actual Score}}{\text{Ideal Score}} \times 100\%$$

$$\% \text{ Ideal Score} = \frac{251}{300} \times 100\%$$

$$\% \text{ Ideal Score} = 83,7\%$$

Respondents' responses based on the aspect of reliability are the ability of the software to maintain a certain level of performance when used under certain conditions [11].

Table 8. Respondents' Responses Based on Efficiency Aspects

Answer Criteria	Weight	Efficiency		Total
		Time Behavior	Resource Utilization	
Strongly agree	5	10	14	24
Agree	4	16	16	32
Neutral	3	4	0	4
Disagree	2	0	0	0
Strongly disagree	1	0	0	0
Number of Respondents		30	30	60
Actual Score		126	134	260
Ideal Score		150	150	300

$$\% \text{ Ideal Score} = \frac{\text{Actual Score}}{\text{Ideal Score}} \times 100\%$$

$$\% \text{ Ideal Score} = \frac{260}{300} \times 100\%$$

$$\% \text{ Ideal Score} = 86,7\%$$

Respondents' responses were based on the efficiency aspect. The efficiency aspect is the ability of the software to provide appropriate performance relative to the number of resources used at that time [11].

Table 9. Respondents' Responses Based on Portability Aspects

Answer Criteria	Weight	Portability	
		Adaptability	Total
Strongly agree	5	27	27
Agree	4	3	3
Neutral	3	0	0
Disagree	2	0	0
Strongly disagree	1	0	0
Number of Respondents		30	60
Actual Score		147	147
Ideal Score		150	300

$$\% \text{ Ideal Score} = \frac{\text{Actual Score}}{\text{Ideal Score}} \times 100\%$$

$$\% \text{ Ideal Score} = \frac{147}{300} \times 100\%$$

$$\% \text{ Ideal Score} = 98,0\%$$

- a. Respondents' Responses Based on Aspects Portability is the software's ability to adapt to a new environment [11].

Table 10. Overall Quality Level

Aspect	Actual Score	Ideal Score	% Actual Score	Criteria
Functionality	429	450	95.3%	Very good
Reliability	251	300	83.7%	Good
Usability	561	600	93.5%	Very good
Efficiency	267	300	89.0%	Very good
Portability	147	150	98.0%	Very good
Total	1655	1800	91.9%	Very good

Based on the results of software testing in this study, it was proven that the ISO 9126 model proved to be very good. According to the respondents, the final result of software quality testing was Very Good, with a response percentage of 91.9%.

4. CONCLUSION

The existence of this Menu Ordering Information System can help make it easier for customers to order menus. By scanning the QR code, customers don't need to call a waiter to streamline the time ordering menus, as evidenced by the score obtained on the efficiency aspect of 86.7%. Ease of use of the system can be

measured by testing the usability aspect, which produces a score of 93.5%. In functionality, it produces a score of 95.3%, meaning that this system runs according to the expected function. Regarding portability, the system gets a score of 98%, which means the system can adapt to the new environment. But in the reliability aspect, it only got a score of 83.7%, which means that improvements in maturity and fault tolerance are still needed so that the system can be even better at handling errors and maturity.

REFERENCE

- [1] R. Auli, A. Zakir, H. Dafitri, and D. Siregar, "Mechanism of Food Ordering in A Restaurant Using Android Technology Mechanism of Food Ordering in A Restaurant Using AndroidTechnology," p. 12030, 2017, doi: 10.1088/1742-6596/930/1/012030.
- [2] Anupama. CG and Anitha D, "Evaluating E-Commerce Application By Customizing Quality Model From Indian Market Perspective", Accessed: Apr. 14, 2023. [Online]. Available: <http://www.ijpam.eu>
- [3] B. D. Juniansyah, E. R. Susanto, and A. D. Wahyudi, "Pembuatan E-Commerce Pemesanan Jasa Event Organizer Untuk Zero Seven Entertainment," *Jurnal Tekno Kompak*, vol. 14, no. 1, pp. 41–46, Feb. 2020, Accessed: Apr. 14, 2023. [Online]. Available: <https://ejurnal.teknokrat.ac.id/index.php/teknokompak/article/view/499>
- [4] B. Behkamal, M. Kahani, and M. K. Akbari, "Customizing ISO 9126 quality model for evaluation of B2B applications," *Information and Software Technology*, vol. 51, no. 3, pp. 599–609, Mar. 2009, doi: 10.1016/J.INFSOF.2008.08.001.
- [5] P. D. A. Pamungkas, "ISO 9126 Untuk Pengujian Kualitas Aplikasi Perpustakaan Senayan Library Management System (SLiMS)," *Jurnal RESTI (Rekayasa Sistem dan Teknologi Informasi)*, vol. 2, no. 2, pp. 465–471, 2018, doi: 10.29207/resti.v2i2.398.
- [6] I. M. Sabpril and A. A. Alfin, "Analysis of Information System Effectiveness Using ISO/IEC 9126 and AHP (Analytical Hierarchy Process) Methods at PT ZYS Analisis Efektivitas Sistem Informasi Menggunakan ISO/IEC 9126 dan Metode AHP (Analytical Hierarchy Process) Pada PT ZYS," *Creative Commons Attribution-NonCommercial-ShareAlike 3.0 Unported License.*, pp. 189–196, 2022.
- [7] B. Ajisaputro, BAjisaputro, "Analisis Pemanfaatan Sistem Informasi Akademik Untuk Meningkatkan Kualitas Sistem Menggunakan Standar ISO 9126," *Jurnal PRODUKTIF*, vol. 6, no. 1, pp. 509–515, 2022.
- [8] T. Heryanto and Y. Yakub, "Analisa Perancangan Sistem Informasi E-Commerce Dengan Metode Object Oriented dan ISO 9126 pada PT.Samudera Semesta Sejahtera," *Tech-E*, vol. 3, no. 1, pp. 33–39, 2019, doi: 10.31253/te.v3i1.201.
- [9] M. Jamil, S. F. Saputra, M. I. Wahid, and D. Riana, "Evaluasi Metode ISO/IEC 9126 Pada Kinerja Website Sistem Informasi Akademik Perguruan Tinggi," *Informatika Mulawarman : Jurnal Ilmiah Ilmu Komputer*, vol. 16, no. 1, pp. 27–33, Mar. 2021, doi: 10.30872/jim.v16i1.5209.
- [10] K. Aprilia and I. Ghazali, *Teknik Penyusunan Skala Likert (Summared Scales)*. Semarang: Fatawa Publishing, 2013.
- [11] T. A. Priambodo, T. Hidayat, and D. Agustine, "SATIN-Sains dan Teknologi Informasi Perancangan Website Sistem Informasi Akademik Sekolah Dasar (Studi Kasus : SDS Arya Jaya Sentika-Tigaraksa Kabupaten Tangerang)," vol. 4, no. 2, 2018.